

www.hypergogo.com
E-Mail: support@hypergogo.com

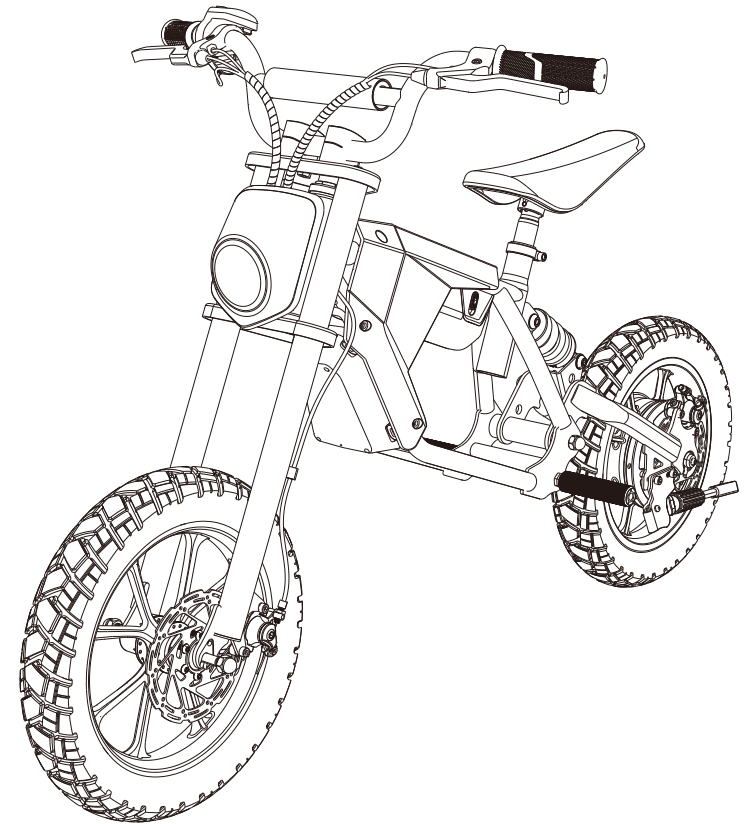

14-INCH ELECTRIC MOTORBIKE USER MANUAL

Model:R8

CONTENTS

WHAT'S IN THE BOX	03
SAFETY RIDING	04-05
ASSEMBLY	06-07
OVERVIEW	08-09
BATTERY ASSEMBLY AND DISASSEMBLY	10
CHARGE YOUR MOTORBIKE	10-11
PREPARATION	12-14
SWITCH ON/ OFF	12
STARTING THE MOTORBIKE.....	13
STOPPING THE MOTORBIKE.....	13
SPEED SWITCH	14
LED LIGHTS	14
SPECIFICATIONS	15
PAIRING YOUR BLUETOOTH DEVICE & APP	16
MAINTENANCE & REPAIR	17-18
MAINTENANCE INSTRUCTIONS	17
SPECIAL ATTENTION INDICATORS	18

THANK YOU!

FOR CHOOSING OUR MOTORBIKE!

BEFORE USING

Read and understand the user manual and all the safety instructions and warnings before using the Motorbike.

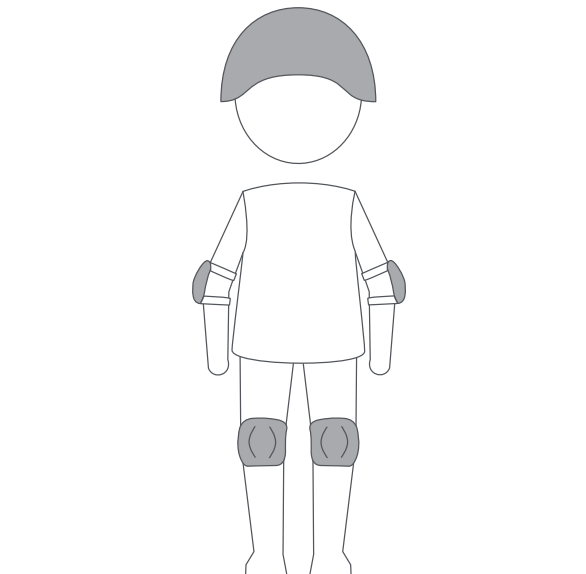

14+ YRS.

WARNING

Allowing children under the age of 14 to operate this Motorbike raises the likelihood of severe injury or even death.

Adult supervision is required for children under the age of 14.

Do not allow children under the age of 14 to operate this Motorbike.

WHAT'S IN THE BOX

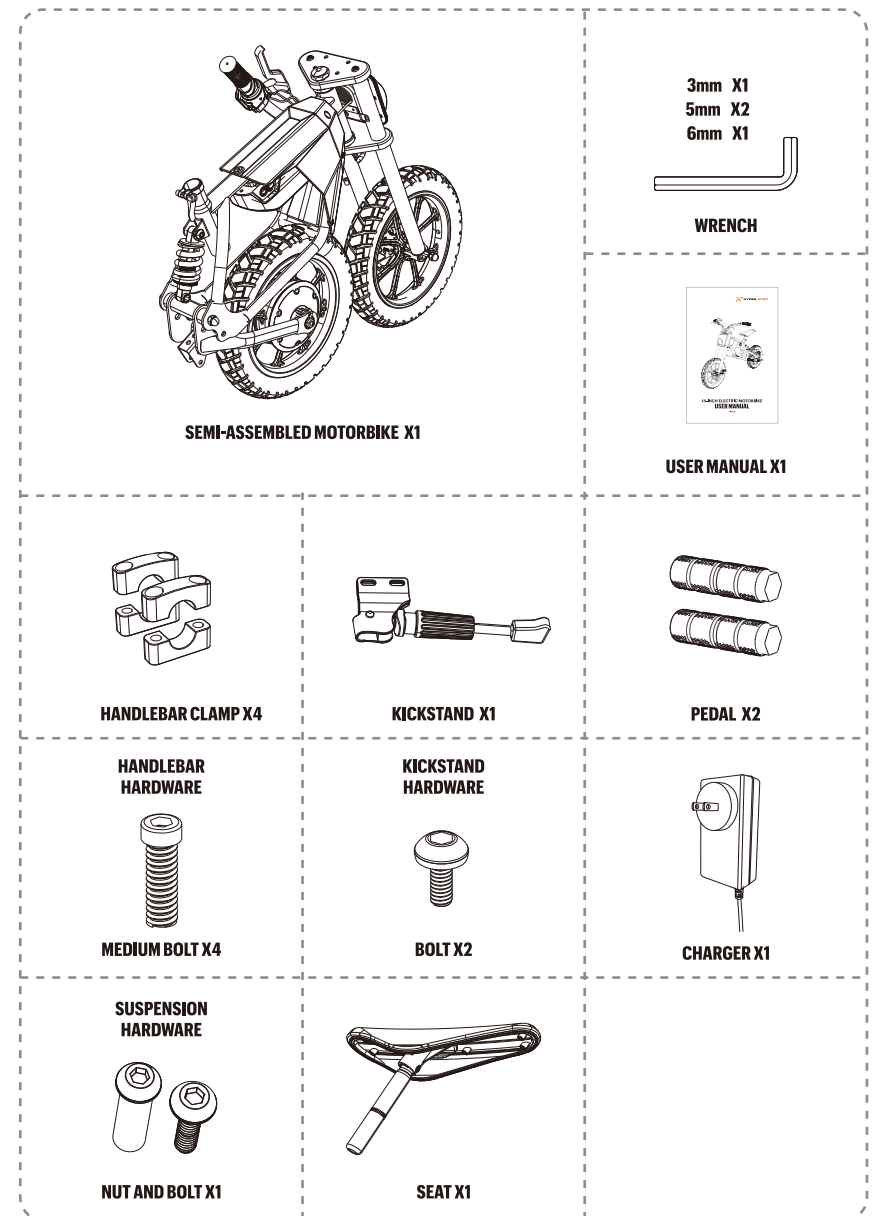

**THE PICTURES IN THE MANUAL ARE JUST FOR REFERENCE.
PLEASE REFER TO THE ACTUAL PRODUCT FOR ACCURACY.**

SAFE RIDING

- Before allowing children to use this Motorbike, adults must thoroughly assess the driving area and the child's ability to safely operate the bike. It is very important that children are taught the appropriate safety rules before they are allowed to ride the Motorbike. In addition, these rules should be reviewed with any other children who wish to operate the Motorbike.
- Remain seated. A child who is not sitting on the seat when the Motorbike is in motion could fall or cause the Motorbike to tip over.
- Do not operate the Motorbike at night.
- Do not operate the Motorbike near steep inclines as it can cause the following:
 - Unsafe speed, even if the throttle is released.
 - Tipping
 - Loss of traction, causing the Motorbike to slip.
 - Rolling backwards at an unsafe speed.
- Avoid contact with moving/rotating parts, such as the motor brake, axle, and wheels. Contact with these parts can cause serious injury.
- Do not operate the Motorbike when it's positioned on its side or upside-down.
- Do not operate the Motorbike near flammable vapors (gasoline, paint thinner, acetone, liquid wax, etc.) as the electrical switch emits an internal spark, which could cause an explosion or fire.
- You should not ride if you are under the influence of alcohol or drugs, if you have a heart condition, are pregnant, have head, back, or neck ailments which limit your ability to ride safely, if you have any mental or physical conditions that may make you susceptible to injury or impair your physical dexterity or mental capabilities to recognize, understand, and perform all of the safety instructions and to be able to assume the hazards inherent with the product.
- Before each use, conduct a basic safety inspection including: (i) condition of tires; (ii) safe operation of brakes and lights; (iii) good condition of the frame; (iv) sufficient battery charge; and (v) any sign of damage, unusual or excessive wear, or other open and obvious mechanical problem/maintenance needs. Components shall be maintained and repaired in accordance with the manufacturer's specifications. Only the manufacturer's authorized replacement parts should be used to service your product.
- Only use on private property. Do not use on public property, streets, or sidewalks. Grass, dirt or other soft terrain are recommended.
- Do not ride aggressively, perform jumps, or take sharp turns. Aggressive riding may damage the product and increase risks.
- Do not carry or tow other products behind the Motorbike for kids.
- Do not use for racing, stunt riding, or other aggressive maneuvers. These types of riding may result in damage to the product and decrease rider control, resulting in injury.



WARNING TO AVOID SERIOUS INJURY:

- Continuous adult supervision is required.
- Never use on roadways, steep inclines or steps, swimming pools, or other bodies of water.
- Never allow more than one rider.
- Riders should always be seated.
- Always wear shoes. Ensure shoes are tied and laces away from the drive and wheels.
- Maximum weight: 165.0 lbs. (75.0kgs).
- Periodically check hardware and tighten it if necessary. Replace worn or broken parts immediately.
- Never use or store in wet conditions.
- For use in large open areas. Avoid collisions.
- Skill is required to avoid falls or collisions.
- Never ride at night.
- Only use the battery specified by the manufacturer.
- Only use the charger specified by the manufacturer.
- Riding the Motorbike for Kids presents potential risks, and caution is required when riding. Inherent hazards are associated with its use (for example, falling off or riding it into a hazardous situation). Adult Supervision is needed, and adults must recognize that a rider can be seriously injured or dead, even when safety precautions are taken. RIDE AT YOUR OWN RISK. Children under 14 years are prohibited from using this product.
- A child must have the required skill level and maturity to ride this product safely. Not all 14-year-olds are equipped to ride the product. Ensure that the rider's physical size, age, weight, maturity, and ability to follow the rules are sufficient before letting your child ride.
- Risk of injury or death from loss of control, collisions, and falls. Always wear a properly fitted helmet and other protective equipment, such as elbow pads and knee pads, as this may be required by local law.
- Always keep two hands on the handlebars at all times.
- Do not touch the brake or motor housing after use. These components may be hot.
- Protective equipment should be worn. Not to be used in traffic.
- Riding on public transportation roads is not allowed.
- This motorbike is unsuitable for children under 14 years of age due to its maximum speed.
- This motorbike contains a battery that is non-replaceable.
- Never use on roadways, near motor vehicles, on or near steep inclines or steps, swimming pools or other bodies of water. Always wear shoes, and never allow more than 1 rider.

ASSEMBLY

ADULTS MUST ASSIST CHILDREN WITH THE ASSEMBLY AND INITIAL ADJUSTMENT PROCEDURES OF THE PRODUCT.

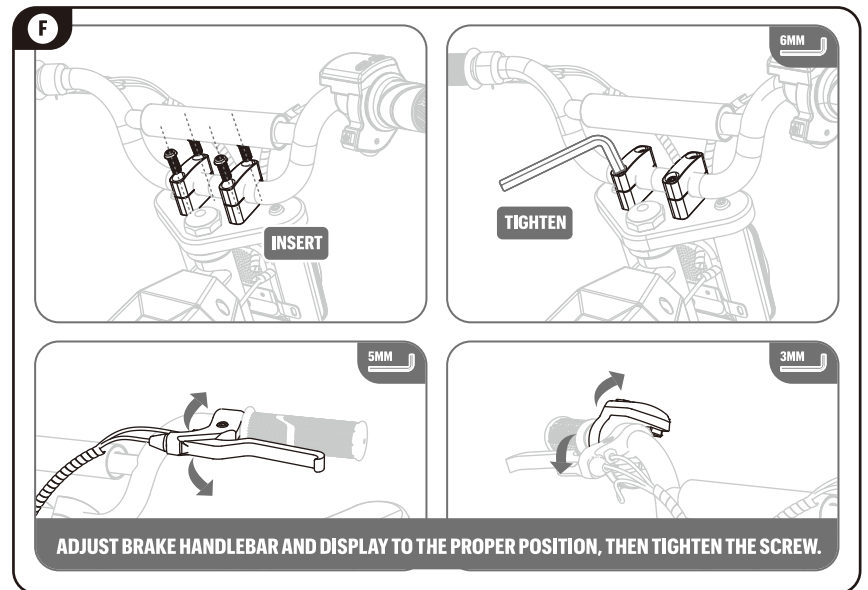
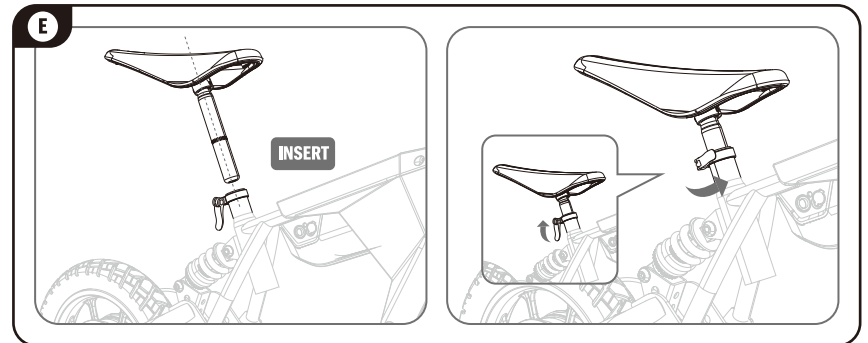
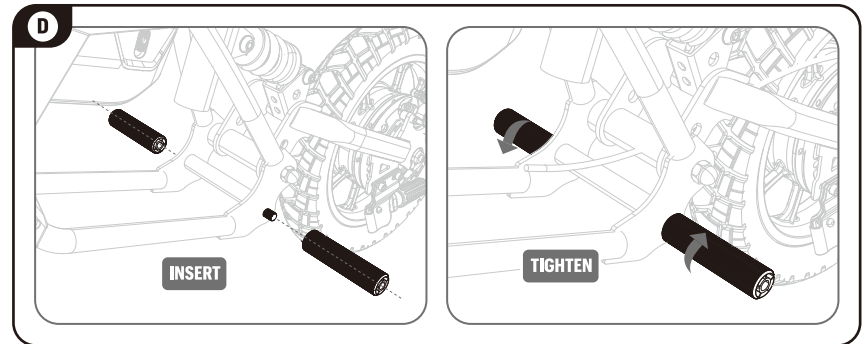
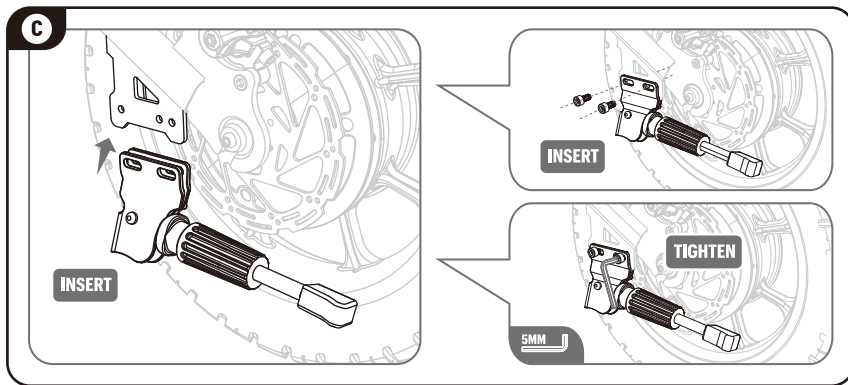
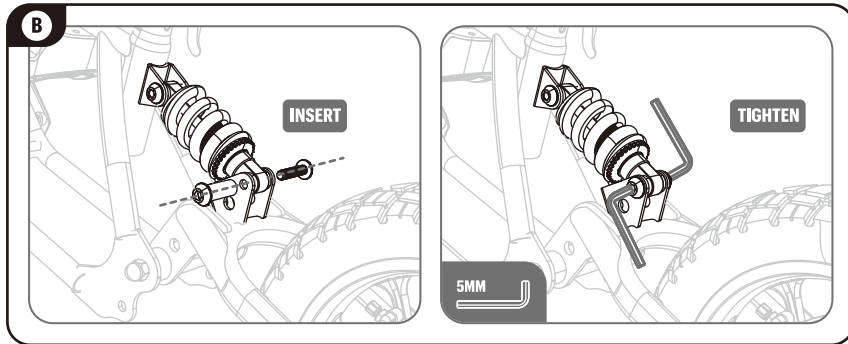
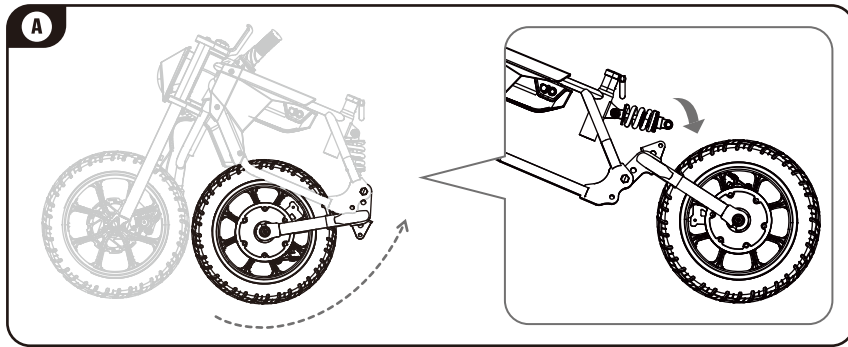

OVERVIEW

The motorbike is designed for recreational use and not meant for transportation purposes.

In order to master riding skills, the rider needs to practice.

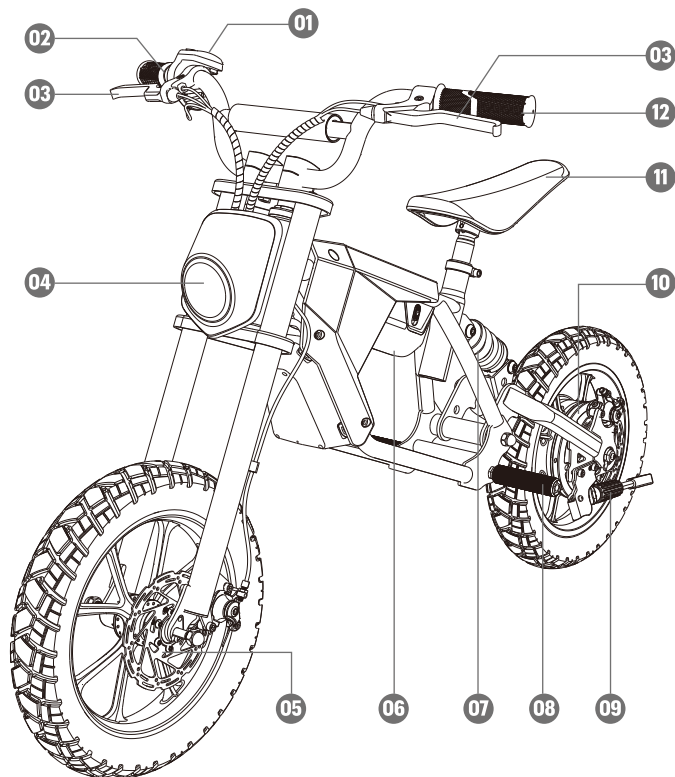

- | | | |
|--------------|---------------|--------------|
| 01 DISPLAY | 05 DISC | 09 KICKSTAND |
| 02 THROTTLE | 06 BATTERY | 10 MOTOR |
| 03 BRAKE | 07 SUSPENSION | 11 SADDLE |
| 04 HEADLIGHT | 08 PEDAL | 12 HANDLEBAR |

THROTTLE INSTRUCTION

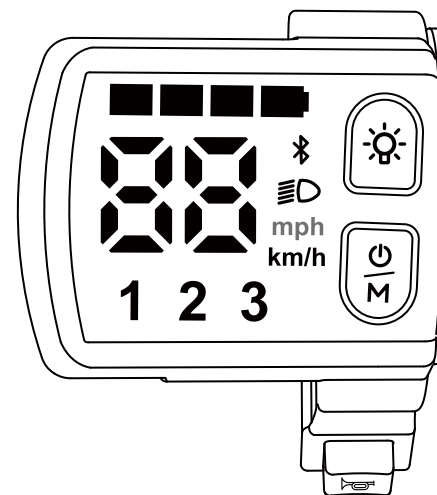

M/G ON/OFF BUTTON

Press and hold for 2 seconds to turn on or off.

Short press once to switch gears.

Short press twice consecutively to switch speed unit.

Press three times quickly to switch engine sound effects.

Press four times quickly to switch full sound effects modes (all sound effects on, standby sound off).

☀️ AMBIENT LIGHT BUTTON

Press for 2 seconds to turn on or off the headlight.

■■■■ BATTERY LEVEL

This icon indicates the battery remaining.

③ ② ① SPEED DISPLAY

This icon indicates the current speed mode.

①: 5mph / ②: 8mph / ③: 10mph

🏠^{km/h} mph SPEED DISPLAY

This icon indicates the current speed in mph.
* Press POWER ON/OFF button 2 times shortly, swift the unit of mph to km/h.

📶 BLUETOOTH

This icon will only appear after APP is successfully connected.

📢 HORN SWITCH

Short press the button to make a ticking sound, long press it to keep ticking sound, you can turn it off/on through APP.

BATTERY ASSEMBLY AND DISASSEMBLY

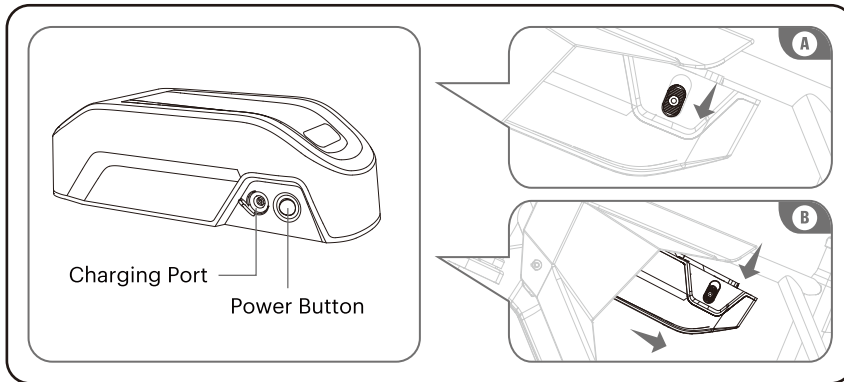

CHARGE YOUR MOTORBIKE

Two Methods of Charging.

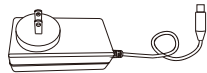

Make sure the Motorbike is in Power Off status while charging.

NOTE: Battery and charger are included. Battery must be fully charged before use. Only use our battery and charger for this product.

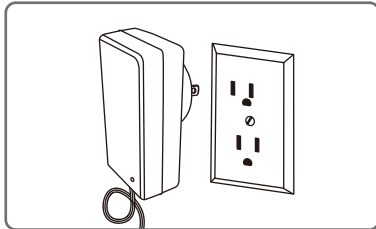

Plug the charger plug into the wall outlet. The light on the charger should be green. Note: 1. Try a different outlet if the green light (LED) does not turn on. 2. The light on the charger will be red during charging and turns green after a full charge.

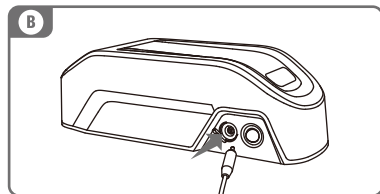
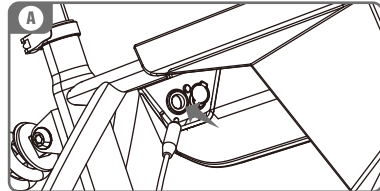

WARNING

Please read all instructions and cautionary markings on the charger and the Motorbike before use.

Note: The battery pack is not fully charged when you first receive it. Before charging, read the safety instructions and follow the proper charging procedures.

- Only use the specified 42V charger to charge this Motorbike. Do not attempt to charge it with any other charger.
- Do not store the Motorbike in locations where the temperature is below 32°F (0°C) or above 122°F (50°C).
- Do not charge the Motorbike in temperatures below 14°F (-10°C) or above 122°F (50°C) as it can cause damage to the battery pack.
- Do not operate the charger if it has been impacted, dropped, or damaged in any way. Before each use, examine the charger and replace it if you find any wear or damage.
- The charger is designed to operate on standard household electrical power (100/240V). Do not attempt to use the charger with any other voltage level.
- Never modify the electrical system as it may result in the risk of electric shock, electrocution, or fire.
- During charging, the Motorbike must be placed in a dry and well-ventilated area.
- To avoid damage to the charger, always pull from the plug rather than the cord when removing it from an outlet.
- Make sure the cord is positioned in a way that it won't be stepped on, tripped over, or subjected to damage or stress.
- An extension cord should only be used if absolutely necessary. The use of an improper extension cord could result in the risk of fire, electric shock, or electrocution.
- To prevent electric shock, do not immerse the charger in water when cleaning. To clean, first remove the charger plug from the outlet and wipe it with a dry cloth.
- Do not place any objects on top of the charger or place the charger on a soft surface that may cause excessive heat. Keep the charger away from any heat sources.

WARNING

This product uses rechargeable lithium batteries. Improper use may cause serious injury or death. Do not charge the product indoor or during sleep.

PREPARATION

- Always wear proper protective equipment, such as an approved safety helmet (with chin strap securely buckled), elbow pads, and knee pads.
- A helmet may be legally required by local law or regulation in your region.
- Always wear shoes and keep shoelaces tied and out of the way of the wheels and motor. Never ride barefooted or in sandals.



SWITCH ON/OFF

- **Turn On:** Press the button for 2 seconds; there will be a ring after turning on.
- **Turn Off:** Press the button for 2 seconds; after “Power off” rings, it turns off.

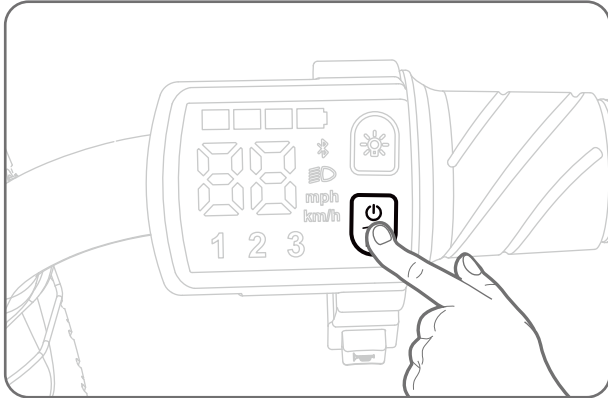

STARTING THE MOTORBIKE

To start the Motorbike, sit on the Motorbike and turn on the power switch. Place both hands on the handlebars and apply the throttle with your right hand.

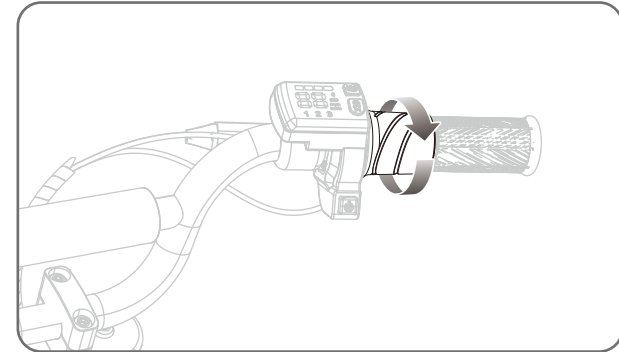

STOPPING THE MOTORBIKE

Squeeze the Brake sound effect when gripping the brake handle, this sound effect is turned off by default and can be turned on and off via APP.

To stop the unit, release the throttle and apply the brakes until the Motorbike comes to a complete stop.

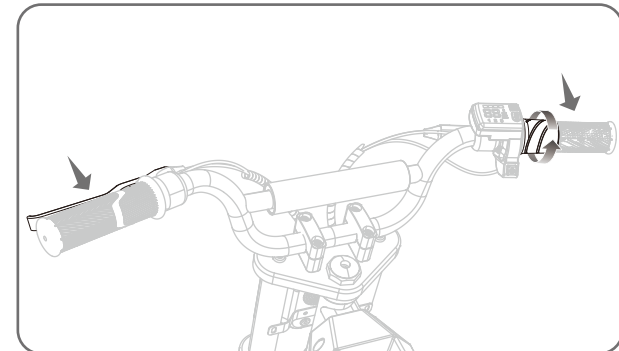

SWITCHING GEARS

The design has three gears, with the default starting gear being toddler mode (①). Simply press the shift button to change gears easily.

The speed can be changed by turning the handle.

① **LOW 5MPH** ② **MID 8MPH** ③ **MAX 10MPH**

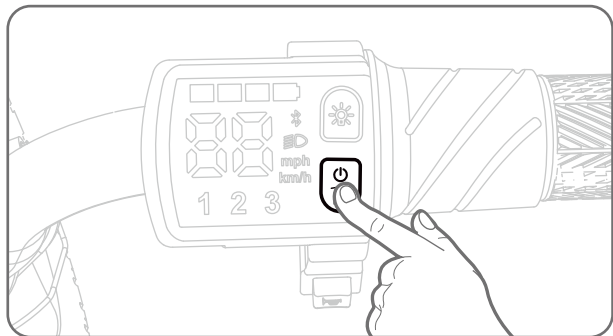

LED LIGHTS

Light-up design on the Motorbike.

When the Motorbike turns on, the lights will be on.

- Press and hold the light button for 2 seconds to turn on or off the headlight.

THE APP CAN BE USED TO TURN ON/OFF AND SWITCH THE LIGHTS.

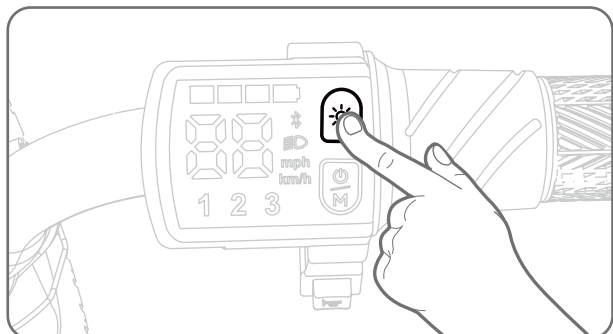

SPECIFICATIONS

MODEL	R8
PRODUCT DIMS (INCH)	L36" X W9.7" X H29.8"
N. W (LBS)	47
BATTERY TYPE	LI-ION 36V 5.2A
INPUT	DC 42V/1.5A
MOTOR	36V 500W
MAX.LOAD (LBS)	165.0
MAX.SPEED(MPH)	10.0
TORQUE (N.M)	41.0
MAX. RANGE (MILES)	15.5
SPEED MODE	3 LEVELS
CHARGE TIME	4 HOURS
TIRES (INCH)	14.0*3.0
DISPLAY	✓
HEADLIGHT	✓
APP	✓
SPEAKER	✓

PAIRING YOUR BLUETOOTH DEVICE

- Ensure both the Bluetooth® function in your device and the Motorbike are turned on.
- Open the Motorbike APP on your device to connect wirelessly to the Motorbike.
- On your device, locate the Bluetooth® device list. Select “Hypergogo” from the list.

APP

Play your Music/Customize LED Lights/3 Speed Modes

- Change the light modes in APP;
- Change the Motorbike working modes in APP.
- Can set any speed in the set-up working mode scope.
 - Kids mode: Max. 10 MPH
 - Normal mode: Max. 13 MPH
 - Sports mode: Max. 15 MPH



MAINTENANCE & REPAIR

WARNING

MAINTENANCE INSTRUCTIONS:

- It is the responsibility of the adult who assembles this product to properly install all parts included in the carton. These instructions are valuable.
- Check nuts and bolts often and tighten if necessary.
- Any parts showing evidence of wear should be replaced immediately.
- Check all screws and their protective coverings regularly and tighten as required. Check plastic parts on a regular basis for cracks or broken pieces.
- During snowy or rainy weather, the Motorbike should be stored inside.
- Do not operate the Motorbike in wet or snowy conditions.
- Do not clean the Motorbike by spraying with a hose. Water or moisture in the motors, battery, or electrical components can cause component failure.
- To clean the Motorbike use a dry cloth. A non-wax furniture polish can be used to clean plastic parts. Do not spray the Motorbike with a hose or submerge it in water.
- Check tire pressure prior to riding. Air may slowly escape if the inner tube has been damaged or punctured, patch or replace the tube if pressure is routinely low prior to riding.
- Inspect tires for wear and tear periodically, the tire tread will wear over time during normal use. Replace the tire once the wear is excessive or impacts product performance.
- Before riding, check the frame and handlebars for cracks or broken connection points. Aggressive riding or crashing into objects may damage or destroy the frame or handlebars. Thoroughly inspect the frame, handlebars, and hardware after any incident and before every ride.

SPECIAL ATTENTION INDICATORS

HEADLIGHT LED	ERROR
E0	Communication failure (the instrument cannot receive data)
E1	Handlebar failure
E2	Brake lever malfunction
E3	Hall sensor error
E4	MOS malfunction
E5	Mainboard malfunction
E6	Battery failure

WARNING

- Devices are not intended for use at elevations greater than 2000 m above sea level. Prolonged exposure to UV rays, rain and the elements may damage the enclosure
- Materials, store Indoors when not in use.
- WARNING – Risk of Fire – No user serviceable parts.
- AVERTISSEMENT- Risque d'incendie et de choc électrique - Aucune des pièces ne peut être réparée par l'utilisateur.

WARNING

- Protective equipment should be worn. Not to be used in traffic.
- The user manual must be retained since it contains important information.
- The Motorbike is intended to be assembled by adult.
- The screwdriver is only used by adults when assembling the motorbike.

AVERTISSEMENT

- Un équipement de protection doit être porté. Ne pas utiliser dans la circulation.
- Le manuel d'utilisation doit être conservé car il contient des informations importantes.
- Le Motorbike est destiné à être assemblé par un adulte.
- Le tournevis n'est utilisé que par les adultes lors de l'assemblage de jouets.

WARNING







- Es muss Schutzausrüstung getragen werden.
- Nicht im Straßenverkehr verwenden.
- Die Bedienungsanleitung muss unbedingt aufbewahrt werden, da sie wichtige Informationen enthält.
- Das Minibike ist für den Zusammenbau durch einen Erwachsenen vorgesehen.
- Der Schraubenzieher wird nur von Erwachsenen beim Zusammenbau von Spielzeug verwendet.

AVVERTIMENTO

- È necessario indossare dispositivi di protezione. Da non utilizzare nel traffico.
- Il manuale utente deve essere conservato poiché contiene informazioni importanti.
- La Motorbike è destinata ad essere assemblata da un adulto.
- Il cacciavite viene utilizzato solo dagli adulti durante il montaggio dei giocattoli.

ADVERTENCIA

- Equipo de protección debe ser usado. No debe utilizarse en el tráfico.
- El manual del usuario debe conservarse ya que contiene información importante.
- La Motorbike está diseñada para que la monte un adulto.
- El destornillador solo lo utilizan adultos para montar juguetes.

	<p>This product complies with the EN15194 standards of the European Community.</p>
<p>RoHS</p>	<p>This product complies with the Restriction of Hazardous Substances in Electrical and Electronic Equipment (RoHS) EU rules restricting the use of hazardous substances in electrical and electronic equipment to protect the environment and public health.</p>
<p>UK CA</p>	<p>This product is in compliance with the applicable requirements for products sold within Great Britain.</p>
	<p>This symbol indicates that the product is capable of being recycled.</p>
	<p>This symbol indicates that the product should not be disposed of as household waste. The product must be sent to separate collection facilities for recovery and recycling of electrical and electronic equipment.</p>
	<p>This symbol indicates that the product inside the packaging could be easily damaged if dropped or handled without care and attention. The contents are fragile!</p>
	<p>This symbol indicates that the product should be kept away from rain and in dry conditions.</p>
	<p>The warning sign indicates a potential hazard, danger, obstacle, or condition requiring special attention.</p>